



THE INSIDE ADVANTAGE™

WHIRLPOOL®

COMMERCIAL LAUNDRY

RESOURCE SAVER®

COMMERCIAL WASHER

Enjoy significant water and energy savings with the Whirlpool® Resource Saver® commercial washer. This commercial washer uses up to 28% less water per load.* By using less water, it also uses less energy – up to 20% per load.* And, as further evidence of our commitment to water and energy savings, Whirlpool® Resource Saver® commercial washers are ENERGY STAR® qualified.

CAW2762K
2-Speed Washer

*Source: Battelle Pacific Northwest Laboratory – testing compares the Resource Saver® washer to a GE baseline top-loading washer.



As an ENERGY STAR® partner, Whirlpool Corporation has determined that products bearing this mark meet the ENERGY STAR® guidelines for energy efficiency.

Delivering Long-Term Performance
through Manufacturing Quality

Water and Energy Savings



Because of their unique design, Resource Saver® washers require less water, less energy, and less money to get clothes completely clean.

Plus, bulky items such as blankets fit easily in the super-capacity basket and its excellent water extraction means less dryer time, for even more savings!

- 3.0 Cu. Ft. Capacity Wash Basket allows you to do larger loads.
- Two Water Levels allow efficient use of the washer for both large and small loads.
- 4 Cycles: Heavy (Hot/Cold), Regular (Warm/Warm), Permanent Press (Warm/Cold), and Colorfast (Cold/Cold) to provide the right washing conditions for a wide range of fabrics.
- Dual-Action, Heavy-Duty Surgilator® Agitator
- Hidden Lid Switch
- Push-Button Controls
- White Cabinet with Stainless-Look Console
- 3/7/10-Year Warranty Protection

CAW2762K – 27" 2-Speed Washer

SPECIFICATIONS AND WARRANTIES

Model	CAW2762K
Electrical Requirements	120V, 3-Wire, 60 Hz. AC, Standard 15-Amp Fuse Branch Circuit (subject to local codes)
Motor	1/2-HP
Motor Speeds	2
Agitate (spm)	180 (high)/120 (low)
Spin (rpm)	640
Shipping Weight – Lb. (approx.)	184
Warranty	
3-Year Limited (parts only)	Entire Product
7-Year Limited (parts only)	Cabinet (against rust)
10-Year Limited (parts only)	Center Post Bearings and Seals
	Wash Basket and Outer Tub



A Nationwide Product and Service Support Network has been established to provide you with valuable information about how Whirlpool® commercial laundry products can help assure your success. Call **1-800-NO-BELTS** (1-800-662-3587) for information and answers to questions about Whirlpool® commercial laundry products.

For more information about Whirlpool® commercial laundry products, visit our website: <http://coinop.com>.

Whirlpool Corporation has a policy of continuous improvement of products and reserves the right to make improvements or changes on products without notice.

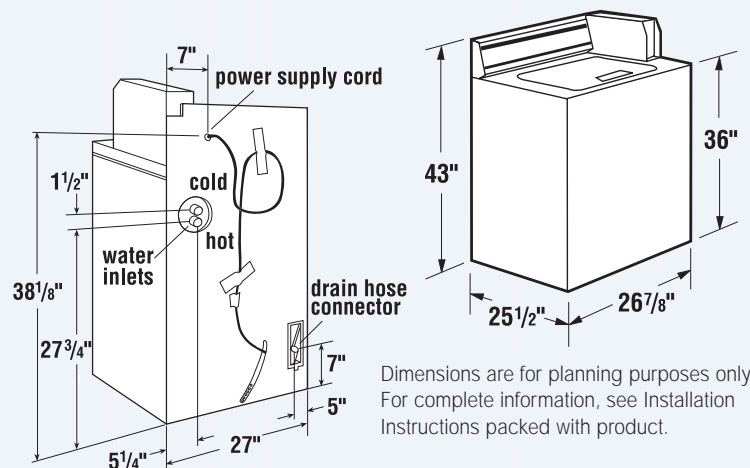

Dimensions are for planning purposes only. For complete information, see Installation Instructions packed with product.



From Whirlpool Corporation – A World Leader in Laundry Products

<http://coinop.com>

®ENERGY STAR is a U.S. registered mark.

®Registered Trademark/™Trademark of Whirlpool, U.S.A.

©2001 Whirlpool Corporation. All rights reserved.

Whirlpool Corporation • Benton Harbor, Michigan 49022 U.S.A.

