



THE INSIDE ADVANTAGE™

WHIRLPOOL®

COMMERCIAL LAUNDRY

A NEW LINE OF COIN-OPERATED

WASHERS AND DRYERS

Whirlpool® coin-operated commercial washers and dryers set the innovative standards for reliability and durability and give you profitability to meet your needs.

CAM2761K
1-Speed Washer

CAM2762K
2-Speed Washer

CEM2760K
Electric Dryer

CGM2761K
Gas Dryer

A close-up, angled photograph of a coin-operated commercial washer. The coin slot is open, revealing the internal mechanism with several rollers and a red and white striped pattern. The machine is white with a stainless steel coin slot area.

Delivering Long-Term Performance
through Manufacturing Quality

COIN-OPERATED COMMERCIAL WASHERS



Model CAM2762K

CAM2761K – 27" 1-Speed Washer **CAM2762K – 27" 2-Speed Washer**

- 2.5 Cu. Ft. Capacity Wash Basket
- 3 Cycles: Regular/Heavy (Hot), Permanent Press (Warm), and Colorfast (Cold) with Cold Rinses
- Reliable, One-Piece Surgilator® Agitator
- 10% Water Savings Option provides savings in water usage and disposal costs (option is owner selectable).
- ½-HP Motor with Built-In Overload Protector
- Direct-Drive Transmission
- Hidden Lid Switch
- Porcelain/Enamel Top and Lid Finish
- Add Fabric Softener Light
- Push-Button Controls
- Easy-to-Follow Lid Instructions
- Galvanized Steel Cabinet with Ultra Guard II Finish
- Stainless Steel, Tamper-Resistant Console Screws
- Commercial-Grade, Color-Coded Water Inlet Hoses with Brass Couplings
- Self-Leveling Rear Legs
- White Cabinet with Stainless-Look Console
- 3/7/10-Year Warranty Protection



Note: Shown with coin box, coin slide, and service lock installed – not supplied by Whirlpool Corporation.



Hidden Lid Switch

To help ensure safe operation, Whirlpool® commercial washers feature a lid switch that is truly hidden. Not only does this prevent tampering, it ensures that the washer will not operate when the lid is open.



Direct-Drive Transmission

The direct-drive transmission is designed for greater dependability. This innovative transmission requires no belts and attaches directly to the motor, further reducing the number of moving parts and increasing reliability.

COIN-OPERATED COMMERCIAL DRYERS



CEM2760K – 27" Electric Dryer CGM2761K – 27" Gas Dryer

- 7.4 Cu. Ft. Drum Capacity – Largest in the Industry!
- 3 Cycles: Regular/Heavy (High Heat), Permanent Press (Medium Heat), and Knits/Delicates (Low Heat)
- **Balanced Airflow System**
- **Large, Door-Mounted Lint Screen (84 sq. in.)**
- 180° Wide-Opening, Side-Swing Door
- Porcelain/Enamel Top Finish
- Front-Service Accessibility
- Four-Way, Multi-Vent Options (back, bottom, and sides)
- ½-HP Motor with Built-In Overload Protector
- Push-Button Controls
- Easy-to-Follow Console Instructions
- White Cabinet with Stainless-Look Console
- **3/7-Year Warranty Protection**



Note: Shown with coin box, coin slide, and service lock installed – not supplied by Whirlpool Corporation.



7.4 Cu. Ft. Capacity

The largest capacity in the industry! The increased capacity allows for large loads of clothes to tumble and spread, saving you and your customers drying time and expense.



Balanced Airflow System

Whirlpool® commercial dryers have an energy-efficient balanced airflow system that circulates air throughout the drum to equalize drying temperatures. With a normal venting system, Whirlpool® commercial dryers have superior back pressure resulting in better airflow and improved drying efficiency.

Whirlpool® Commercial Laundry Products give you all you expect from the World's Largest Manufacturer of Home Appliances!

SPECIFICATIONS AND WARRANTIES

Model	Washers		Electric Dryer	Gas Dryer
	CAM2761K	CAM2762K	CEM2760K	CGM2761K
Electrical Requirements	120V, 3-Wire, 60 Hz. AC, Standard 15-Amp Fuse Branch Circuit (subject to local codes)	120V, 3-Wire, 60 Hz. AC, Standard 15-Amp Fuse Branch Circuit (subject to local codes)	240V, 3-Wire, 60 Hz. AC, Standard 30-Amp Fuse Branch Circuit (subject to local codes)	120V, 3-Wire, 60 Hz. AC, Standard 15-Amp Fuse Branch Circuit (subject to local codes)
Motor	1/2-HP	1/2-HP	1/3-HP	1/3-HP
Motor Speed(s)	1	2	—	—
Agitate (spm)	180	180 (high) 120 (low)	—	—
Spin (rpm)	640	640	—	—
Heat Source	—	—	5,600 Watts	22,000 BTU Nat.*
Shipping Weight – Lb. (approx.)	184	184	134	138
Warranty				
3-Year Limited (parts only)	Entire Product	Entire Product	Entire Product	Entire Product
7-Year Limited (parts only)	Cabinet (against rust)	Cabinet (against rust)	Cabinet (against rust)	Cabinet (against rust)
	Center Post Bearings and Seals	Center Post Bearings and Seals	—	—
10-Year Limited (parts only)	Wash Basket and Outer Tub	Wash Basket and Outer Tub	—	—

*LP Conversion Kit: 694572

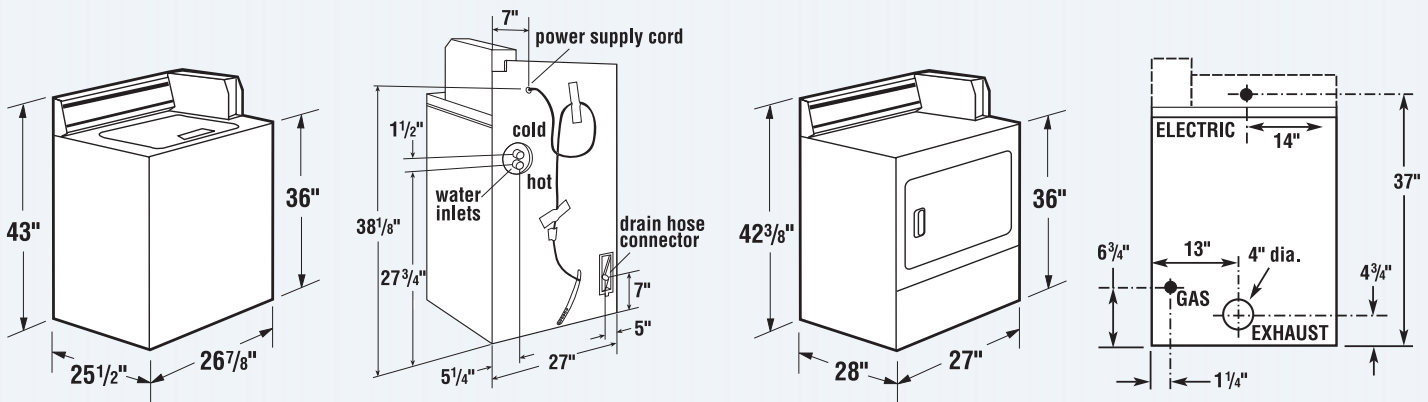

Dimensions are for planning purposes only. For complete information, see Installation Instructions packed with product.

A Nationwide Product and Service Support Network has been established to provide you with valuable information about how Whirlpool® commercial laundry products can help assure your success. Call **1-800-NO-BELTS** (1-800-662-3587) for information and answers to questions about Whirlpool® commercial laundry products.

For more information about Whirlpool® commercial laundry products, visit our website: <http://coinop.com>.

Whirlpool Corporation has a policy of continuous improvement of products and reserves the right to make improvements or changes on products without notice.



From Whirlpool Corporation – A World Leader in Laundry Products

<http://coinop.com>

©Registered Trademark™Trademark of Whirlpool, U.S.A.

©2001 Whirlpool Corporation. All rights reserved.

Whirlpool Corporation • Benton Harbor, Michigan 49022 U.S.A.

