



THE INSIDE ADVANTAGE™

# WHIRLPOOL®

## COIN-KIT-INSTALLED

### COMMERCIAL

### LAUNDRY PRODUCTS

---

CAM2752K  
Washer

---

CEM2750K  
Electric Dryer

---

CGM2751K  
Gas Dryer

---

Delivering Long-Term Performance  
through Manufacturing Quality



## COIN-OPERATED COMMERCIAL WASHERS



### CAM2752K – 27" 2-Speed Washer

- Coin Kit is installed and ready for operation!
- 2.5 Cu. Ft. Capacity Wash Basket
- 3 Cycles: Regular/Heavy (Hot), Permanent Press (Warm), and Colorfast (Cold) with Cold Rinses
- Reliable, One-Piece Surgilator® Agitator
- Selectable Wash Speeds
- 10% Water Savings Option provides savings in water usage and disposal costs (option is owner selectable).
- ½-HP Motor with Built-In Overload Protector
- Direct-Drive Transmission
- Hidden Lid Switch
- Porcelain/Enamel Top and Lid Finish
- Add Fabric Softener Light
- Push-Button Controls
- Easy-to-Follow Lid Instructions
- Galvanized Steel Cabinet with Ultra Guard II Finish
- Stainless Steel, Tamper-Resistant Console Screws
- Commercial-Grade, Color-Coded Water Inlet Hoses with Brass Couplings
- Self-Leveling Rear Legs
- White Cabinet with Stainless-Look Console
- 3/7/10-Year Warranty Protection



#### *Coin Kit*

For your convenience, the coin kit (coin box/key/slide) is already installed so you can begin coin operation immediately. Vendor price is factory set at \$1.00. Instructions for changing the vendor price are shipped with the unit, along with 50¢, 75¢, and \$1.25 stickers.



#### *Direct-Drive Transmission*

The direct-drive transmission is designed for greater dependability. This innovative transmission requires no belts and attaches directly to the motor, further reducing the number of moving parts and increasing reliability.

## COIN-OPERATED COMMERCIAL DRYERS



### CEM2750K – 27" Electric Dryer CGM2751K – 27" Gas Dryer

- Coin kit is installed and ready for operation!
- 7.4 Cu. Ft. Drum Capacity – Largest in the Industry!
- 3 Cycles: Regular/Heavy (High Heat), Permanent Press (Medium Heat), and Knits/Delicates (Low Heat)
- **Balanced Airflow System**
- **Large, Door-Mounted Lint Screen (84 sq. in.)**
- 180° Wide-Opening, Side-Swing Door
- **Porcelain/Enamel Top Finish**
- Front-Service Accessibility
- Four-Way, Multi-Vent Options (back, bottom, and sides)
- ½-HP Motor with Built-In Overload Protector
- Push-Button Controls
- Easy-to-Follow Console Instructions
- White Cabinet with Stainless-Look Console
- **3/7-Year Warranty Protection**



#### **7.4 Cu. Ft. Capacity**

The largest capacity in the industry! The increased capacity allows for large loads of clothes to tumble and spread, saving you and your customers drying time and expense.



#### **Balanced Airflow System**

Whirlpool® commercial dryers have an energy-efficient balanced airflow system that circulates air throughout the drum to equalize drying temperatures. With a normal venting system, Whirlpool® commercial dryers have superior back pressure resulting in better airflow and improved drying efficiency.

# Whirlpool® Commercial Laundry Products give you all you expect from the World's Largest Manufacturer of Home Appliances!

## SPECIFICATIONS AND WARRANTIES

| Model                           | Washer  | Electric Dryer  | Gas Dryer   |
|---------------------------------|---|---|---|
|                                 | CAM2752K  | CEM2750K  | CGM2751K  |
| Electrical Requirements         | 120V, 3-Wire, 60 Hz, AC, Standard 15-Amp Fuse Branch Circuit (subject to local codes) | 240V, 3-Wire, 60 Hz, AC, Standard 30-Amp Fuse Branch Circuit (subject to local codes) | 120V, 3-Wire, 60 Hz, AC, Standard 15-Amp Fuse Branch Circuit (subject to local codes) |
| Motor                           | ½-HP  | ½-HP  | ½-HP  |
| Motor Speeds                    | 2   | —   | —   |
| Agitate (spm)                   | 180 high<br>120 low   | —   | —   |
| Spin (rpm)                      | 640   | —   | —   |
| Heat Source                     | —   | 5,600 Watts   | 22,000 BTU Nat.*  |
| Shipping Weight – Lb. (approx.) | 190   | 140   | 144   |
| Warranty                        |   |   |   |
| 3-Year Limited (parts only)     | Entire Product  | Entire Product  | Entire Product  |
| 7-Year Limited (parts only)     | Cabinet (against rust)  | Cabinet (against rust)  | Cabinet (against rust)  |
|                                 | Center Post Bearings and Seals  | —   | —   |
| 10-Year Limited (parts only)    | Wash Basket and Outer Tub   | —   | —   |

\*LP Conversion Kit: 694572

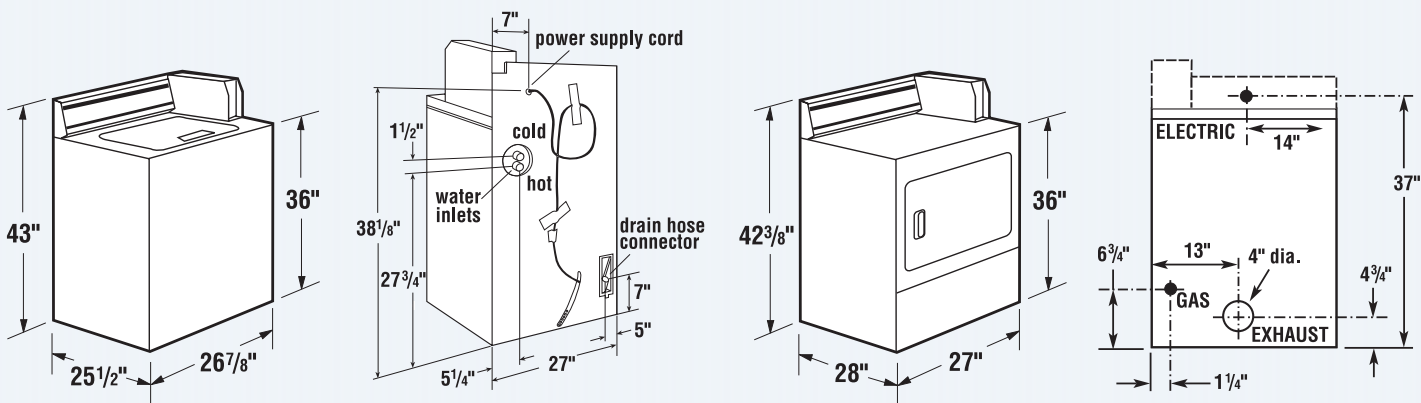

Dimensions are for planning purposes only.  
For complete information, see Installation  
Instructions packed with product.

A Nationwide Product and Service Support Network has been established to provide you with valuable information about how Whirlpool® commercial laundry products can help assure your success. Call **1-800-NO-BELTS** (1-800-662-3587) for information and answers to questions about Whirlpool® commercial laundry products.

For more information about Whirlpool® commercial laundry products, visit our website: <http://coinop.com>.

Whirlpool Corporation has a policy of continuous improvement of products and reserves the right to make improvements or changes on products without notice.



From Whirlpool Corporation – A World Leader in Laundry Products

<http://coinop.com>

©Registered Trademark™Trademark of Whirlpool, U.S.A.

©2001 Whirlpool Corporation. All rights reserved.

Whirlpool Corporation • Benton Harbor, Michigan 49022 U.S.A.

