

ADVANTECH™ WASHERS – COIN-READY



Model CAE2762K

CAE2761K – 27" 1-Speed Washer CAE2762K – 27" 2-Speed Washer

- ADVANTECH™ Electronic Control System interfaces with money acceptor options (coin drop, coin slide, smart card)
- Easy-to-Upgrade Data Management Software that is compatible with a Palm™ handheld computer
- LED Display: Vend Price, Cycle Time, and Cycle Counter
- 2.5 Cu. Ft. Capacity Wash Basket
- 3 Cycles: Cotton (Hot), Wrinkle Free (Warm), and Colorfast (Cold)
- Reliable, One-Piece Surgilator® Agitator
- ½-HP Motor with Built-In Overload Protector
- **Hidden Lid Switch**
- White Cabinet with Stainless-Look Console
- **4/7/10-Year Warranty Protection**



Hidden Lid Switch

To help ensure safe operation, Whirlpool® commercial washers feature a lid switch that is truly hidden. Not only does this prevent tampering, it ensures that the washer will not operate when the lid is open.

Whirlpool® Commercial Laundry Products give you all you expect from the World's Largest Manufacturer of Home Appliances!

SPECIFICATIONS AND WARRANTIES

Model	Washers		
	CAE2761K	CAE2762K	CAE2792K
Electrical Requirements	120V, 3-Wire, 60 Hz, AC, Standard 15-Amp Fuse Branch Circuit (subject to local codes)		
Motor	½-HP	½-HP	½-HP
Motor Speed(s)	1	2	2
Agitate (spm)	180	180 (high)/120 (low)	180 (high)/120 (low)
Spin (rpm)	640	640	640
Shipping Weight – Lb. (approx.)	184	184	173
Warranty	Entire Product including Electronic Controls		
4-Year Limited (parts only)	Cabinet (against rust)		
7-Year Limited (parts only)	Center Post Bearings and Seals		
10-Year Limited (parts only)	Wash Basket and Outer Tub		

Model	Electric Dryers	Gas Dryers
	CEE2760K CEE2790K	CGE2761K CGE2791K
Electrical Requirements	240V, 3-Wire, 60 Hz, AC, Standard 30-Amp Fuse Branch Circuit (subject to local codes)	120V, 3-Wire, 60 Hz, AC, Standard 15-Amp Fuse Branch Circuit (subject to local codes)
Motor	½-HP	½-HP
Heat Source	5,600 Watts	22,000 BTU Nat.*
Shipping Weight – Lb. (approx.)	CEE2760K – 133 CEE2790K – 122	CGE2761K – 135 CGE2791K – 124
Warranty	Entire Product	
4-Year Limited (parts only)	Cabinet (against rust)	
7-Year Limited (parts only)	Cabinet (against rust)	

*LP Conversion Kit: 694572

A Nationwide Product and Service Support Network has been established to provide you with valuable information about how Whirlpool® commercial laundry products can help assure your success. Call **1-800-NO-BELTS** (1-800-662-3587) for information and answers to questions about Whirlpool® commercial laundry products.

For more information about Whirlpool® commercial laundry products, visit our website: <http://coinop.com>.

Whirlpool Corporation has a policy of continuous improvement of products and reserves the right to make improvements or changes on products without notice.

Dimensions are for planning purposes only. For complete information, see Installation Instructions packed with product.

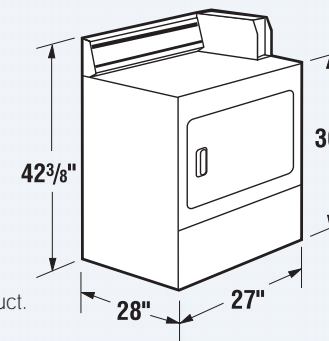
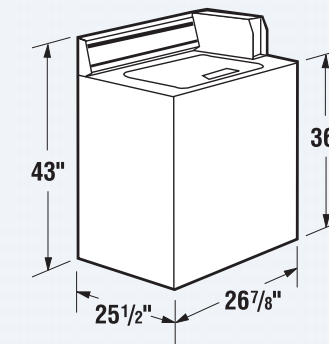

From Whirlpool Corporation – A World Leader in Laundry Products
<http://coinop.com>

™Palm is a Trademark of Palm, Inc.
©Registered Trademark/™Trademark of Whirlpool, U.S.A.
©2001 Whirlpool Corporation. All rights reserved.
Whirlpool Corporation • Benton Harbor, Michigan 49022 U.S.A.

06/01
Form No. CWLL082



(22722RC0601)
Printed in U.S.A.



THE INSIDE ADVANTAGE™

WHIRLPOOL®

ADVANTECH™

COMMERCIAL

LAUNDRY PRODUCTS

CAE2761K

1-Speed Washer with
ADVANTECH™ Control
and Meter Case

CAE2762K

2-Speed Washer with
ADVANTECH™ Control
and Meter Case

CAE2792K

2-Speed Washer with
ADVANTECH™ Control

CEE2760K

Electric Dryer with
ADVANTECH™ Control
and Meter Case

CGE2761K

Gas Dryer with
ADVANTECH™ Control
and Meter Case

CEE2790K

Electric Dryer with
ADVANTECH™ Control

CGE2791K

Gas Dryer with
ADVANTECH™ Control

Delivering Long-Term Performance
through Manufacturing Quality

ADVANTECH™ WASHER – SMART CARD-READY



CAE2792K – 27" 2-Speed Washer

- ADVANTECH™ Electronic Control System interfaces with major smart card systems
- Easy-to-Upgrade Data Management Software that is compatible with a Palm™ handheld computer
- LED Display: Vend Price, Cycle Time, Cycle Counter, and Current Balance from smart card system
- 2.5 Cu. Ft. Capacity Wash Basket
- 3 Cycles: Cotton (Hot), Wrinkle Free (Warm), and Colorfast (Cold)
- Dual-Action Surgilator® Agitator
- ½-HP Motor with Built-In Overload Protector
- **Hidden Lid Switch**
- White Cabinet with Stainless-Look Console
- **4/7/10-Year Warranty Protection**



ADVANTECH™ Electronic Control System Benefits

- Provides interfaces for coin slides, coin drops, or smart card kits. If it's necessary to move an appliance to a new location and/or change the money acceptor, the ADVANTECH™ Electronic Control System is adaptable - there's no loss of data.
- The open communication architecture between the controller and the smart card allows compatibility with major smart card systems.

- Onboard flash memory allows appliance upgrades to be downloaded from a handheld computer without changing memory chips or controllers. Software cannot be lost during a power outage.
- Machine setups can be stored on a handheld computer and beamed to the appliance for repeated machine installations without setup errors. Smart card data collection is available if a handheld computer is not used.

ADVANTECH™ DRYERS – COIN-READY



CEE2760K – 27" Electric Dryer CGE2761K – 27" Gas Dryer

- ADVANTECH™ Electronic Control System interfaces with money acceptor options (coin drop, coin slide, smart card)
- Easy-to-Upgrade Data Management Software that is compatible with a Palm™ handheld computer
- LED Display: Vend Price and Cycle Time
- **7.4 Cu. Ft. Drum Capacity – Largest in the Industry!**
- 3 Cycles: Regular/Heavy (High Heat), Permanent Press (Medium Heat), and Knits/Delicates (Low Heat)
- Fabric Protection Cool-Down Care
- Balanced Airflow System
- 180° Wide-Opening, Side-Swing Door
- ½-HP Motor with Built-In Overload Protector
- White Cabinet with Stainless-Look Console
- **4/7-Year Warranty Protection**



7.4 Cu. Ft. Capacity
The largest capacity in the industry! The increased capacity allows for large loads of clothes to tumble and spread, saving you and your customers drying time and expense.

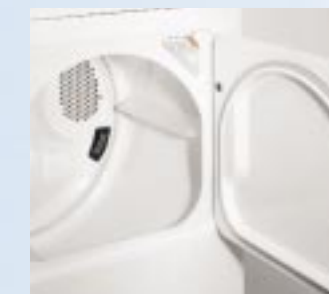

Side-Swing Door
For convenient access, the wide-opening side-swing door can be opened a full 180°.

ADVANTECH™ DRYERS – SMART CARD-READY



CEE2790K – 27" Electric Dryer CGE2791K – 27" Gas Dryer

- ADVANTECH™ Electronic Control System interfaces with major smart card systems
- Easy-to-Upgrade Data Management Software that is compatible with a Palm™ handheld computer
- LED Display: Vend Price, Cycle Time, and Current Balance from smart card system
- **7.4 Cu. Ft. Drum Capacity – Largest in the Industry!**
- 3 Cycles: Regular/Heavy (High Heat), Permanent Press (Medium Heat), and Knits/Delicates (Low Heat)
- Fabric Protection Cool-Down Care
- Balanced Airflow System
- 180° Wide-Opening, Side-Swing Door
- ½-HP Motor with Built-In Overload Protector
- White Cabinet with Stainless-Look Console
- **4/7-Year Warranty Protection**



Balanced Airflow System
Whirlpool® commercial dryers have an energy-efficient balanced airflow system that circulates air throughout the drum to equalize drying temperatures. With a normal venting system, Whirlpool® commercial dryers have superior back pressure resulting in better airflow and improved drying efficiency.