



THE INSIDE ADVANTAGE™

WHIRLPOOL®

ON-PREMISE

LAUNDRY PRODUCTS

Property and business owners are enjoying increased profitability through on-site, commercial laundry products. And when it comes to reliable, commercial laundry products, there's really only one name to know – Whirlpool Corporation. For your convenience, these models feature commercial performance.



GCAM2701J –
Washer

GCEM2900J –
Electric Dryer

GCGM2901J –
Gas Dryer

Delivering Long-Term Performance through Manufacturing Quality

On-Premise Washer



GCAM2701J – 27" Single-Speed Washer

- **3.0 Cu. Ft. Capacity Wash Basket**
- 10% Water Savings Option provides savings in water usage and disposal costs (option is owner selectable).
- 3 Cycles: Regular/Heavy (Hot), Permanent Press (Warm), Colorfast (Cold)
- Reliable, One-Piece Surgilator® Agitator
- **Direct-Drive, ½-HP Motor**
- ToughTop II™ Polyester/Enamel Top and Lid Finish
- Add Fabric Softener Light
- Push-Button Controls
- **Self-Leveling Rear Legs**
- Commercial-Grade, Color-Coded Water Inlet Hoses with Brass Couplings
- 1-3-5 Warranty Protection (see back page for details)
- White-on-White Styling



3.0 Cu. Ft. Capacity Wash Basket – Super capacity wash basket is ideal for handling family-size loads.

Direct-Drive, ½-HP Motor – A Whirlpool brand trademark. The direct-drive, no-belt transmission features greater reliability – which means reduced downtime and increased profits!

Self-Leveling Rear Legs level washer automatically without manual adjustments; compensate for floors that are uneven by as much as 1½ inches.

On-Premise Dryers

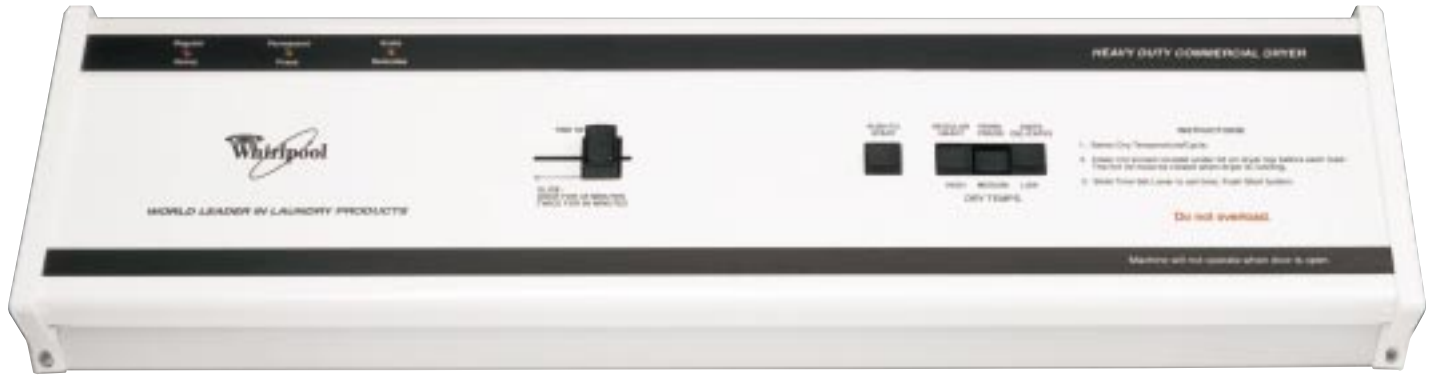

GCEM2900J – 29" Electric Dryer GCGM2901J – 29" Gas Dryer

- **7.0 Cu. Ft. Capacity Drum**
- **3 Cycles:** Regular/Heavy (High Heat), Permanent Press (Medium Heat), Knits/Delicates (Low Heat)
- **Balanced Airflow System**
- **Large, Top-Mounted Metal Lint Screen (99 sq. in.)**
- **Super Wide-Opening Side-Swing Door**
- **ToughTop II™ Polyester/Enamel Top Finish**
- **½-HP Motor with Built-In Overload Protector**
- **Push-Button Controls**
- **Easy-to-Follow Console Instructions**
- **1-3 Warranty Protection (see back page for details)**
- **White-on-White Styling**



7.0 Cu. Ft. Capacity Drum – Provides a large capacity for clothes to tumble and spread; saves drying time. Smooth, DuraWhite™ finish resists rust and helps prevent snagging; increases in-the-drum visibility.

Balanced Airflow System – You want a dryer that is energy efficient and dependable. Your customers want a dryer that can get clothes dry faster and more efficiently. The key is tumbling – which allows wrinkle-free, uniform drying results. These Whirlpool® commercial dryers circulate air throughout the drum to help equalize drying temperatures and control linting.

Large, Top-Mounted Metal Lint Screen (99 sq. in.) – Largest in the Industry! Easy to remove and clean. Large surface area provides maximum unrestricted air flow for efficient drying. Durable fine-mesh metal screen is rust- and corrosion-resistant.

Super Wide-Opening Side-Swing Door – Permits easy loading and unloading of clothes and checking of drying progress.

Whirlpool® Commercial Laundry Products give you all you expect from the #1 Appliance Manufacturer in the World!



THE INSIDE ADVANTAGE™

- Long-Lasting Warranty Protection
- Responsive Customer Service
- High Quality
- Most Experience

SPECIFICATIONS

Washer

- Motor: ½-hp, 120V, 60 Hz., AC
- Agitate speed – 180 spm; spin speed 640 rpm (approx.)
- Color-coded fill hoses with brass couplings and drain hose included.
- Shipping weight: 173 lb

Electric Dryer

- Motor: ½-hp with built-in overload protector; centrifugal switch turns off heating element when motor stops.
- 3-wire nominal, 240/208V, 60 Hz., AC, standard 30-amp. fuse branch circuit (subject to local codes).
- Wattage: 5600/5200 total heater watts
- 208V Conversion Kit: 3398069
- Shipping weight: 122 lb

Gas Dryer

- Motor: ½-hp with built-in overload protector; centrifugal switch turns off gas burner when motor stops.
- 22,000 BTU (natural gas) per hour. Burner orifices are available for manufactured, natural, mixed, or LP gas with varying BTU ranges.
- Electrical: Nominal, 120V, 60 Hz., AC (subject to local codes).
- LP Conversion Kit: 694572
- Shipping weight: 124 lb

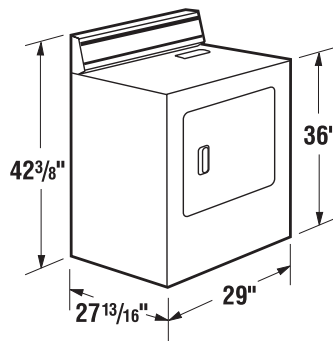
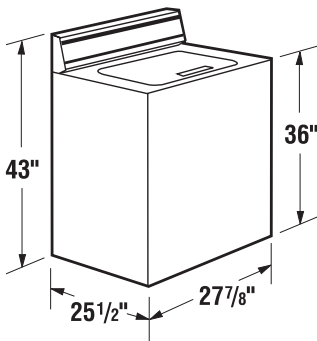

Dimensions are for planning purposes only. For complete information, see Installation Instructions packed with product.

WHIRLPOOL™ WARRANTY AND SERVICE*

Our Commitment to Your Long-Term Success

WASHERS

Length	Type	Covers
1-Year Warranty	Full (parts & labor)	Entire product
3-Year Warranty	Limited (parts only)	Entire product
5-Year Warranty	Limited (parts only)	Outer tub

DRYERS

Length	Type	Covers
1-Year Warranty	Full (parts & labor)	Entire product
3-Year Warranty	Limited (parts only)	Entire product

*See dealer for details.

A Nationwide Product and Service Support Network has been established to provide you with valuable information about how Whirlpool® Commercial Laundry Products can help assure your success. Call **1-800-NO-BELTS** (1-800-662-3587) for information and answers to questions about Whirlpool® Commercial Laundry Products.

FSP® Replacement Parts fills most orders within 24 hours, reducing downtime.

For more information about our line of Commercial Laundry Products, you can find us on the Internet under: <http://coinop.com>.

In-warranty and out-of-warranty service is available from a nationwide network of Whirlpool designated service companies.

Whirlpool Corporation has a policy of continuous improvement of products and reserves the right to make improvements or changes on products without notice.

From Whirlpool Corporation – A World Leader in Laundry Products

<http://coinop.com>

®Registered Trademark/™Trademark of Whirlpool, U.S.A.
©2000 Whirlpool Corporation. All rights reserved.

Whirlpool Corporation • Benton Harbor, Michigan 49022 U.S.A.

