



THE INSIDE ADVANTAGE™

# COMMERCIAL LAUNDRY PRODUCTS

WITH EMS2000 ELECTRONIC

MANAGEMENT SYSTEM AND

SMART CARD OPERATION

CAE2792E –  
2-Speed Washer

CEE2990E –  
Electric Dryer

CGE2991E –  
Gas Dryer



**The Smart Alternative in Commercial Laundry**

## Smart Card Operation – Your Key to Success!

Whirlpool™ EMS2000 Electronic Management System Commercial Laundry Products Smart Card Operation offers a new level of control that minimizes error, waste, and pilferage, while maximizing profits – without the need for expensive retrofit units. The Smart Card performs all programming, operating, auditing, and diagnostic functions – electronically! You get maximum selectivity, flexibility, and versatility all in one convenient card – the Smart Card.

**Programming** – Quick and Easy! Inserting your Smart Card allows you to access a wide variety of options in just seconds. Customize your Vend Price, Cycle Times, and Cycle Options

to maximize your competitive edge. Vend price no longer limits you to 25¢ increments – you can now increase and decrease in any adjustment from .01 to 99.99.

**Operating** – No coins, no meter cases, and no “silent partners”! With the Smart Card, no money is needed to operate Whirlpool® EMS2000 Commercial Laundry Products, which also means no coin collection costs. The laundry system is activated by the Smart Card, and card usage is redeemed only at your establishment, which ties your customers to you.

**Auditing** – Machine accountability and auditing provides complete historical data for total system control on a per machine basis. Track machine history for revenue received, cycle usage, and day and time-of-day usage.

**Diagnostic** – The Smart Card offers the flexibility of being able to enter the system diagnostic test in mid-cycle as well as between cycles. The expanded electronic diagnostic system helps identify potential mechanical failures to reduce costly downtime and expensive service calls.

Note: To purchase the Smart Card System, call Whirlpool at 1-800-662-3587 or contact Greenwald Industries Inc, at 212 Middlesex Avenue, Chester, CT 06412, or phone (860) 526-0800.



Smart Card – Electronic Management System

# EMS2000 – A New Level of Style and Performance

Full-Featured Vacuum Fluorescent (VF) Display

Color-Coded Graphics

Step-by-Step Console Instructions

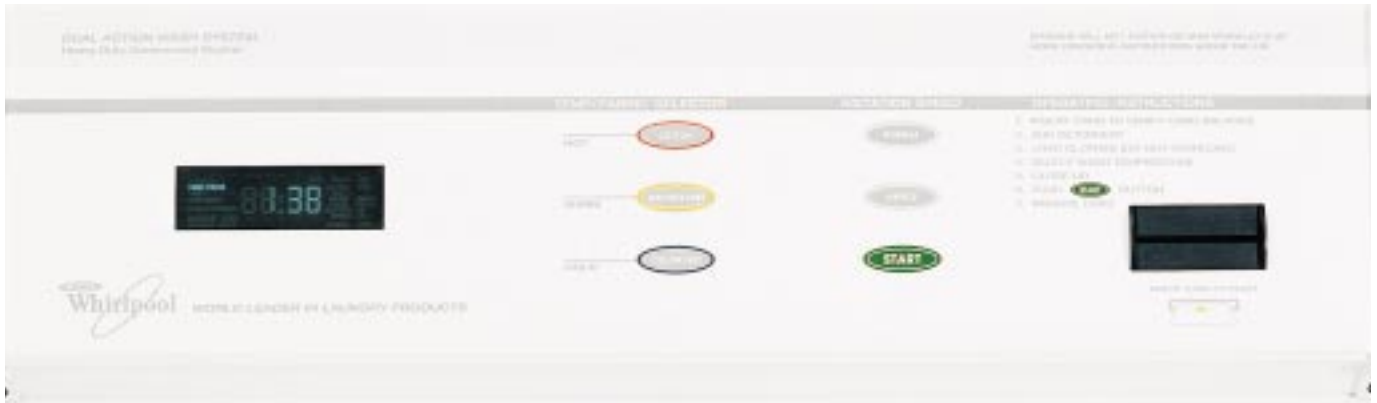

## Cost-Efficient Electronics

- **Expanded Electronic System** – A dependable alternative to mechanical switches and timer.
- **VF Displayed Cycle Counter, Cycle Options, and Audit System.**
- **Cycle and Vend Price Options** maximize revenues. Increase and decrease adjustments in cycle time, cycle options, and vend price structure on a per machine basis. Simply insert your Smart Card and program your option.

## User-Friendly Operation

- **Color-Coded Graphics** take the guesswork out of matching fabric types to wash and dry temperature settings. **Red** indicates hot wash temp for cotton and high dry temp for regular/heavy, **Yellow** indicates warm wash temp and medium dry temp for wrinkle free, and **Blue** indicates cold wash temp or colorfast and low dry temp for knits/gentle.
- **VF Displayed Vend Price Options, Cycle Selected, Cycle-Time Countdown, and Current Card Balance**, graphics confirm selection and cycle progress.
- **Push-to-Start Control** ensures safe, dependable operation.
- **Operating Instructions on Console and Lid Instructions** provide an easy-to-understand operating guide.

## Contemporary Styling

- **Ultra Touch™ Controls** with membrane switch provide easy, touch-pad operation. Smooth surface has no seams or cracks to trap dirt and detergents.
- **Dura-Print™ Finish Console** won't fade or wear off. Resists chipping and scratching; provides a rust- and corrosion-resistant surface. Wipes clean easily too!
- **Color-Coded Graphics** – Smartly styled red, yellow, and blue graphics visually indicate selected wash/dry temperature settings.
- **Color-Coordinated Exterior** – From the end caps to the console you'll find color-coordinated styling that's pleasing to the eye. And, by combining our Ultra Touch™ Console with Dura-Print™ Finish, your commercial laundry equipment offers a clean, state-of-the-art appearance.

# EMS2000 – Protecting Your Investment...

## Washer Features:

- **Large 2.5 Cu. Ft. Capacity** – 31.7 gallon maximum fill water consumption.\* 10% Water-Savings Option reduces water consumption to 27.7 gallons per cycle.\*
- **Super Rust-Resistant Cabinet** with a galvanized extra-thick front panel and galvanized side panels.
- **Porcelain Top and Lid Finish** resists rust, chipping, and scratches.
- **Heavy-Duty Surgilator® Agitator** delivers dual action – a key to effective cleaning.
- **No-Belt Direct-Drive Transmission** – No belts or pulleys and fewer moving parts mean dependable operation.
- **Polypropylene Outer Tub** provides a durable surface. And, because it's made of polypropylene, the tub will never rust or corrode...ever!
- **Exclusive 2-3-5-7 Limited Warranty Protection** includes an industry exclusive electronic board replacement (with exchange only) – our commitment to your long-term success. (See back page for details.)

\*Based on 14-lb AHAM load.



Heavy-Duty Surgilator® Agitator



No-Belt Direct-Drive Transmission

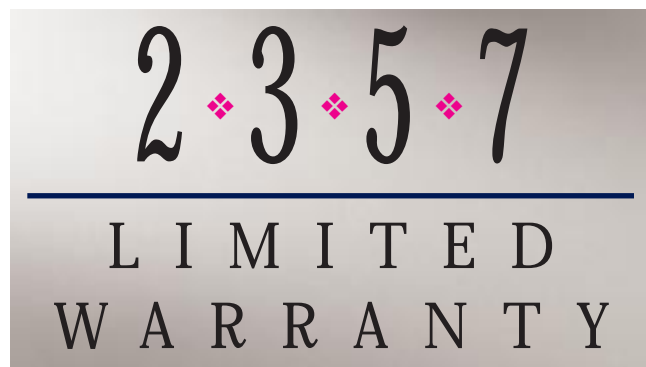

Exclusive 2-3-5-7 Warranty Protection

# EMS2000 – The Smart Alternative in Commercial Laundry



## Washer Model CAE2792E

### EMS2000 with Smart Card Operation Plus:

- **Three Automatic Cycles** – Cotton (Hot Wash), Wrinkle Free (Warm Wash), and Colorfast (Cold Wash) with Cold Rinse.
- **Two-Speed Agitation Selector** allows user to tailor washing needs. Select high (180 spm) or low (120 spm) to match agitation speed to fabric type.
- **Programmable Extra Rinse, Extra Agitation, Extra Spin, and Warm Rinse Cycle Options** offer you a competitive edge in your establishment (options are owner selectable).
- **10% Water-Savings Option** provides savings in water usage and disposal costs (option is owner selectable).
- **VF Displayed Agitation Speed Selected and Add Softener Indicator.**
- **Heavy-Duty ½-HP Overload-Protected Capacitor-Start Motor.**
- **Tripod 3-Point Suspension System** enables washer to attain high spin speeds for greater water extraction.
- **Wide-Opening Lid** permits easy loading and unloading.
- **Galvanized Steel Cabinet with Ultra Guard II Finish** includes a front panel that has extra reinforcement. This cabinet will maintain its “like new” look year after year.
- **Tilt-Back Console** conveniently raises for quick and easy access to service electronic controls.
- **Stainless Steel, Tamper-Resistant Console Screws**
- **Removable, Full-Length Front Panel** provides easy access to the motor and pump to ensure 100% front serviceability.
- **Rear Access Water Inlet Valve** provides a convenient access for connecting all hoses or servicing the water inlet assembly.
- **Self-Leveling Rear Legs** level washer automatically without manual adjustments; compensate for floors that are uneven by as much as 1½ inches.
- **Commercial-Grade, Color-Coded Water Inlet Hoses with Brass Couplings** are designed for long-life performance – and preferred by commercial washer owners.
- **Color-Coordinated White Styling.**



## EMS2000 – Protecting Your Investment...



7.0 Cu. Ft. Capacity Drum with DuraWhite™ Finish

**2 Year**  

---

**LIMITED WARRANTY**

### Dryer Features:

- **7.0 Cu. Ft. Capacity Drum with DuraWhite™ Finish** – Large capacity provides more room for clothes to tumble and spread; saves drying time. Smooth epoxy/polyester drum finish resists rust and prevents snagging of fabrics; increases in-the-drum visibility.
- **180° Super Wide-Opening, Reversible Side-Swing Door with Safety Switch** permits easy loading and unloading of clothes; reversible door provides an easy solution to limited space problems.
- **Large, Corrosion-Resistant Top-Mounted Lint Screen (99 sq. in.)** increases unrestricted airflow for more efficient drying. Conveniently located for easy access. Largest in the industry!
- **Porcelain Top Finish** resists rust, chipping, and scratches.
- **2-Year Limited Warranty Protection** – Our commitment to your long-term success. (See back page for details.)



180° Super Wide-Opening, Reversible Side-Swing Door with Safety Switch

# EMS2000 – The Smart Alternative in Commercial Laundry



## Dryer Models CEE2990E (Electric), CGE2991E (Gas) EMS2000 with Smart Card Operation Plus:

- **Three Automatic Cycles** – Cotton (High Heat), Wrinkle Free (Medium Heat) and Knits/Gentle (Low Heat). Factory-set at 45-minutes with 2 through 99 minute set dry times. Increase and decrease dry times in 1-minute increments without changing the timing cams.
- **Accumulation Cycle-Time and Top-Off Options** help maximize revenues on a per machine basis.
- **Fabric Protection Cool-Down Care** helps clothes dry virtually wrinkle-free.
- **Balanced Airflow Drying System** provides the controlled temperatures necessary to uniformly dry a variety of fabrics.
- **½-HP Motor with Built-In Overload Protector**; centrifugal switch turns off heating element or gas burner when motor stops.
- **Baffles** lift and spread clothes in a varied tumbling pattern to ensure thorough, even drying.
- **Thermal Fuse/Thermal Cutoff** ensures safe, yet effective operation.
- **Commercial-Grade 4-Rib Drum Belt** provides dependable, long-term performance.
- **Baked Acrylic/Enamel Cabinet Finish** resists chipping and scratching; provides a rust- and corrosion-resistant surface.
- **Color-Coordinated White Styling.**



# Specifications



THE INSIDE ADVANTAGE™

**Washer** – 120V, 60 Hz., A.C.  
**Shipping Weight** – 173 lb

**Electric Dryer** – 3-wire nominal, 240/208V, 60 Hz., A.C., standard 30-amp. fuse branch circuit for each dryer (subject to local codes).  
**Wattage** – 5,600/5,200 total heater watts.  
**208V conversion kit:** 3398069.  
**Shipping Weight** – 122 lb

**Gas Dryer** – 22,000 BTU per hour. Burner orifices are available for manufactured, natural, mixed, and LP gas with varying BTU ratings.  
**Electrical** – Nominal, 120V, 60 Hz., A.C. for each dryer (subject to local codes). LP conversion kit: 694572.  
**Shipping Weight** – 124 lb

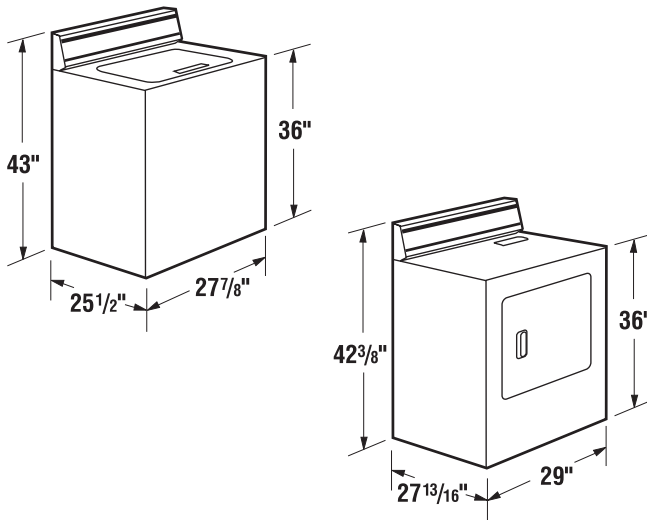

Dimensions are for planning purposes only.  
For complete information, see Installation Instructions packed with product.

## Whirlpool™ Warranty and Service – Our Commitment to Your Long-Term Success

**WASHERS:** One of the most comprehensive warranties in the industry, Whirlpool™ 2-3-5-7 Warranty Protection Program goes even further to assure your satisfaction. A two-year limited warranty, from the date of purchase, covers parts for the entire product. The second-through-third year limited warranty covers the gearcase assembly, rust-through protection on the cabinet assembly, and, with exchange only, the industry exclusive electronic board replacement. A second-through-fifth year limited warranty covers the outer tub's parts. A second-through-seventh year limited warranty covers parts for the assembly, center post bearings, and seals.

**DRYERS:** A two-year limited warranty, from the date of purchase, covers parts to correct defects in materials and workmanship.

For complete warranty information, see your dealer or the warranty packed with product.

A Nationwide Product and Service Support Network has been established to provide you with valuable information about how Whirlpool® Commercial Laundry Products can help assure your success. Call **1-800-NO-BELTS** (1-800-662-3587) for information and answers to questions about Whirlpool® Commercial Laundry Products.

FSP® Replacement Parts fills most orders within 24 hours, reducing downtime.

For more information about our line of Commercial Laundry Products, you can find us on the internet under <http://coinop.com>.

In-warranty/out-of-warranty service is available from a nationwide network of Whirlpool designated service companies.

Whirlpool Corporation has a policy of continuous improvement of products and reserves the right to make improvements or changes on products without notice.



From Whirlpool Corporation – A World Leader in Laundry Products  
<http://coinop.com>

®Registered Trademark™Trademark of Whirlpool, U.S.A.  
©2000 Whirlpool Corporation. All rights reserved.

Whirlpool Corporation • Benton Harbor, Michigan 49022 U.S.A.