



THE INSIDE ADVANTAGE™

WHIRLPOOL®

COMMERCIAL LAUNDRY

WITH EMS 1000

ELECTRONIC CONTROLS

CAP2761K
Washer

CEP2760K
Electric Dryer

CGP2761K
Gas Dryer



Delivering Long-Term Performance
through Manufacturing Quality

COIN-OPERATED COMMERCIAL WASHERS



CAP2761K – 27" 1-Speed Washer

- Expanded Electronic System is a dependable alternative to a mechanical switch and timer
- **Non-Resetttable LED Displayed Cycle Counter ensures that customer payments and employee collections are accounted for and accurate**
- Vend Price Option maximizes revenue. Increase and decrease adjustments in vend price on a per machine basis. Simply activate the system security switch (located inside the meter case) and program your options using the specified Ultra Touch™ pad.
- 2.5 Cu. Ft. Capacity Wash Basket
- 3 Cycles: Cotton (Hot), Wrinkle Free (Warm), and Colorfast (Cold)
- Reliable, One-Piece Surgilator® Agitator
- ½-HP Motor with Built-In Overload Protector
- **Direct-Drive Transmission**
- **Hidden Lid Switch**
- Porcelain/Enamel Top and Lid Finish
- **Galvanized Steel Cabinet with Ultra Guard II Finish**
- Tilt-Back Console conveniently raises for quick and easy access to service electronic controls
- **Stainless Steel, Tamper-Resistant Console Screws**
- **Removable, Full-Length Front Panel for front service accessibility**
- Commercial-Grade, Color-Coded Water Inlet Hoses with Brass Couplings
- **Self-Leveling Rear Legs**
- White Cabinet with Stainless-Look Console
- **3/7/10-Year Warranty Protection**



Note: Shown with coin box, coin slide, and service lock installed – not supplied by Whirlpool Corporation.



Hidden Lid Switch

To help ensure safe operation, Whirlpool® commercial washers feature a lid switch that is truly hidden. Not only does this prevent tampering, it ensures that the washer will not operate when the lid is open.

COIN-OPERATED COMMERCIAL DRYERS



CEP2760K – 27" Electric Dryer CGP2761K – 27" Gas Dryer

- Expanded Electronic System is a dependable alternative to a mechanical switch and timer
- **Non-Resettable LED Displayed Cycle Counter ensures that customer payments and employee collections are accounted for and accurate**
- Cycle and Vend Price Options maximize revenues. Increase and decrease adjustments in cycle time and vend price on a per machine basis. Simply activate the system security switch (located inside the meter case) and program your options using the specified Ultra Touch™ pad.
- **7.4 Cu. Ft. Drum Capacity – Largest in the Industry!**
- 3 Cycles: Regular/Heavy (High Heat), Permanent Press (Medium Heat), and Knits/Delicates (Low Heat)
- **Balanced Airflow System**
- **Large, Door-Mounted Lint Screen (84 sq. in.)**
- 180° Wide-Opening, Side-Swing Door
- Porcelain/Enamel Top Finish
- Front Service Accessibility
- Four-Way, Multi-Vent Options (back, bottom, and sides)
- ½-HP Motor with Built-In Overload Protector
- White Cabinet with Stainless-Look Console
- **3/7-Year Warranty Protection**

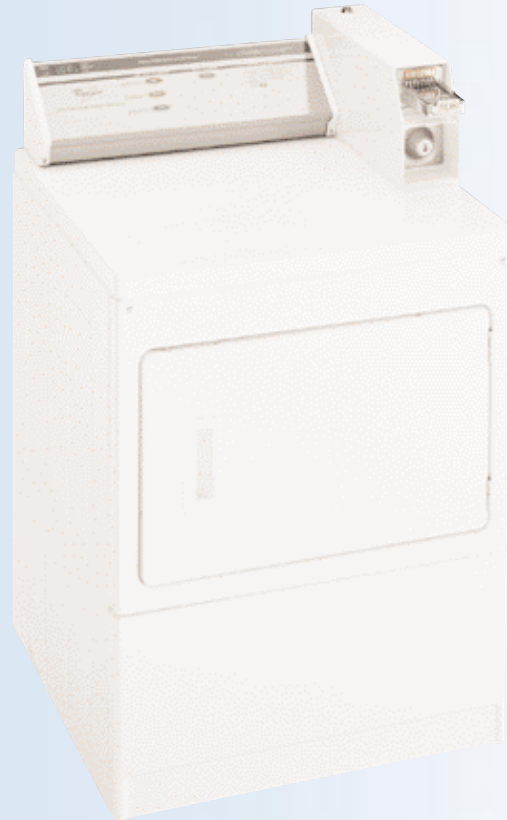

Note: Shown with coin box, coin slide, and service lock installed – not supplied by Whirlpool Corporation.



Balanced Airflow System

Whirlpool® commercial dryers have an energy-efficient balanced airflow system that circulates air throughout the drum to equalize drying temperatures. With a normal venting system, Whirlpool® commercial dryers have superior back pressure resulting in better airflow and improved drying efficiency.



7.4 Cu. Ft. Capacity

The largest capacity in the industry! The increased capacity allows for large loads of clothes to tumble and spread, saving you and your customers drying time and expense.

Whirlpool® Commercial Laundry Products give you all you expect from the World's Largest Manufacturer of Home Appliances!

SPECIFICATIONS AND WARRANTIES

Model	Washer	Electric Dryer	Gas Dryer
	CAP2761K	CEP2760K	CGP2761K
Electrical Requirements	120V, 3-Wire, 60 Hz, AC, Standard 15-Amp Fuse Branch Circuit (subject to local codes)	240V, 3-Wire, 60 Hz, AC, Standard 30-Amp Fuse Branch Circuit (subject to local codes)	120V, 3-Wire, 60 Hz, AC, Standard 15-Amp Fuse Branch Circuit (subject to local codes)
Motor	1/2-HP	1/3-HP	1/3-HP
Agitate Speed (spm)	180	—	—
Spin Speed (rpm)	640	—	—
Heat Source	—	5,600 Watts	22,000 BTU Nat.*
Shipping Weight – Lb. (approx.)	184	133	135
Warranty			
3-Year Limited (parts only)	Entire Product	Entire Product	Entire Product
7-Year Limited (parts only)	Cabinet (against rust)	Cabinet (against rust)	Cabinet (against rust)
	Center Post Bearings and Seals	—	—
10-Year Limited (parts only)	Wash Basket and Outer Tub	—	—

*LP Conversion Kit: 694572

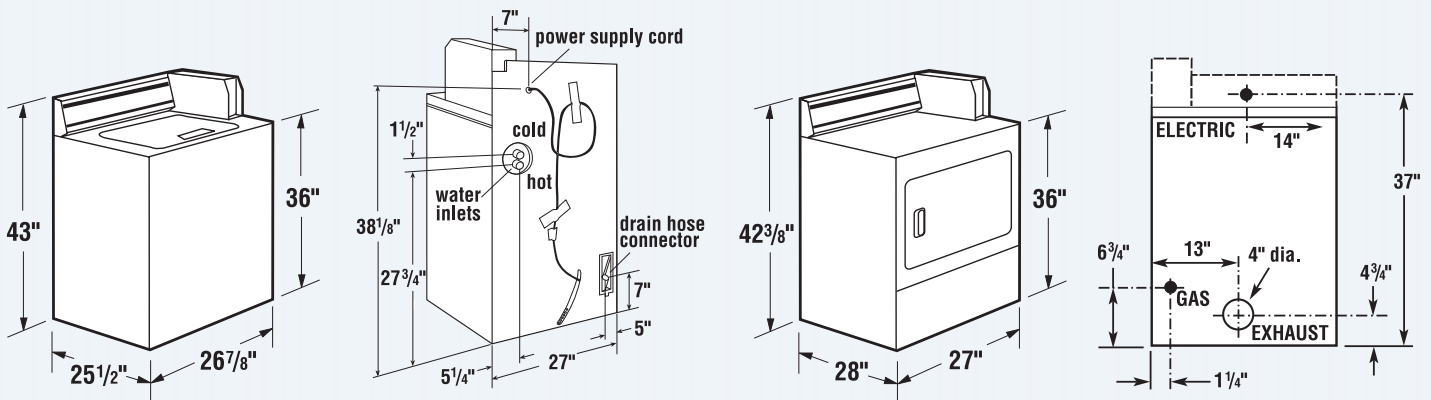

Dimensions are for planning purposes only.
For complete information, see Installation Instructions packed with product.

A Nationwide Product and Service Support Network has been established to provide you with valuable information about how Whirlpool® commercial laundry products can help assure your success. Call **1-800-NO-BELTS** (1-800-662-3587) for information and answers to questions about Whirlpool® commercial laundry products.

For more information about Whirlpool® commercial laundry products, visit our website: <http://coinop.com>.

Whirlpool Corporation has a policy of continuous improvement of products and reserves the right to make improvements or changes on products without notice.

From Whirlpool Corporation – A World Leader in Laundry Products

<http://coinop.com>

®Registered Trademark™Trademark of Whirlpool, U.S.A.

©2001 Whirlpool Corporation. All rights reserved.

Whirlpool Corporation • Benton Harbor, Michigan 49022 U.S.A.

